



SZ 50Hz

Fluorin Plastic Centrifugal Pump



Nanfang Pump Industry Co., Ltd.
CNP Headquarter
Address: Renhe Town, Hangzhou, China
Post code: 311107
Tel: +86-571-86397837, 86397810
Fax: +86-571-86397809
E-mail: info@nanfang-pump.com
www.cnppump.com

E200507
subject to amendments



Stock code: 300145

Pumping Water Pumping Honor



Company profile

Nanfang Pump Industry Co.,Ltd (CNP),as a subsidiary of Nanfang Zhongjin Environment Co.,Ltd, was founded in 1991,and listed on Shenzhen Stock Exchange on December 9,2010 with stock code 300145.

In 2019, CNP's annual output exceeded 900,000 units/set with nearly 3 billion sales revenue, continuing to maintain high growth.

As a national enterprise technology center, CNP has flagship ultra-high efficient product -new generation CDM (F) light vertical multistage centrifugal pump, $MEI \geq 0.7$. Same series high temperature pump products are developed in 2019 to satisfy high temperature applications. All light stainless steel pump product series grow stably. Advanced frequency conversion water supply equipment has been innovated to the 6th generation. Fire pump and diesel engine have obtained UL certification. TD in-line pump, NIS/NISO end suction pump, NSC split casing pump, WQ sewage pump, PQ stainless steel fountain submersible pump, BP silent tube pump, pool pump, non-blocking self-priming sewage pump, metering pump, oil pump and other pump products, can meet various application needs of different fields.

CNP has a complete sales network both in domestic and overseas market,exporting to over 60 countries and regions, maintaining long-term and strong relationship with our clients. CNP pumps have been widely applied in various fields like water treatment、water supply and drainage、HVAC、industrial application、seawater desalination、energy and power etc.

CNP, a green water expert beside you.

Content

Model definition	1
Structure features	1
Typical application	1
Operating condition	1
Motor	1
Curve conditions	1
Performance curve	1
Installation conditions	1
Performance range	2
Performance table	2
Sectional drawing	3
Material	3
SZ25/SZ40/SZ50 Performance curves	4
Installation sketch	7
SZ25/SZ40/SZ50 Corrosion resistance table	8

Model definition

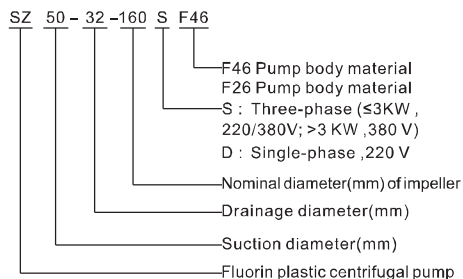

Structure feature

- SZ pump has one impeller, axial suction and radical discharge.
- Simple structure, shaft is directly connected with impeller. Easy for pipe works, inlet and outlet are connected by standard flanges.
- Wet parts are made of fluorin plastic (F26, F46), accessories are made of cast iron (HT200)

Typical application

- Any concentration of acid alkali, salty solution, strong oxidants, organic solvent etc. Strongly corrosive medium.
- Petrol, chemical, pesticide, acid cleaning, dying, paper making, galvanization, etc.

Operation conditions

- Thin medium not containing grain or fiber.
- Medium temperature: -20°C-120°C
- Medium density: Max $1.35 \times 10^3 \text{ kg/m}^3$
- Ambient temperature: Max +40°C
- Altitude: Max 1000m
- Pressure: Max 10bar

Motor

- TEFC motor, 2 pole
- Protection class: IP 55
- Insulation level: CLASS F
- Standard voltage: 50HZ, 3×380V

Curve conditions

- All curves are based on the measured value of constant motor speed 2900rpm, 50Hz, 3 x 380V.
- The measurements were made with airless water at temperature of 20°C. The curves apply to a kinematic viscosity of $1 \text{ mm}^2/\text{s}$ (1cst)
- It is suggested to operate the pump in the scope of the bold curve, to prevent motor from overload
- When pumping liquids with a density higher than that of the operation conditions, use motors with correspondingly higher outputs.
- Curve tolerance conforms with ISO9906: 2012 Grade 3B.

Performance curve

- Q/H: means the curve of the flow and head at the nominal rotating speed
- Power curve: P2 means the pump input power, if the medium density is $1 \times 10^3 \text{ kg/m}^3$
- Efficient curve: Eta means the pump efficient

Installation conditions

- When installation, please make sure the pump would not be effected by the pipeline force when pump operation.
- The pump should be strongly fixed on the horizontal base.
- In order to make motor work well, pump should be installed on the frozen-free and ventilate place.
- The electric protection devices should protect pump from being damaged by phase lack, unstable voltage, electric leakage, overload.

Performance range

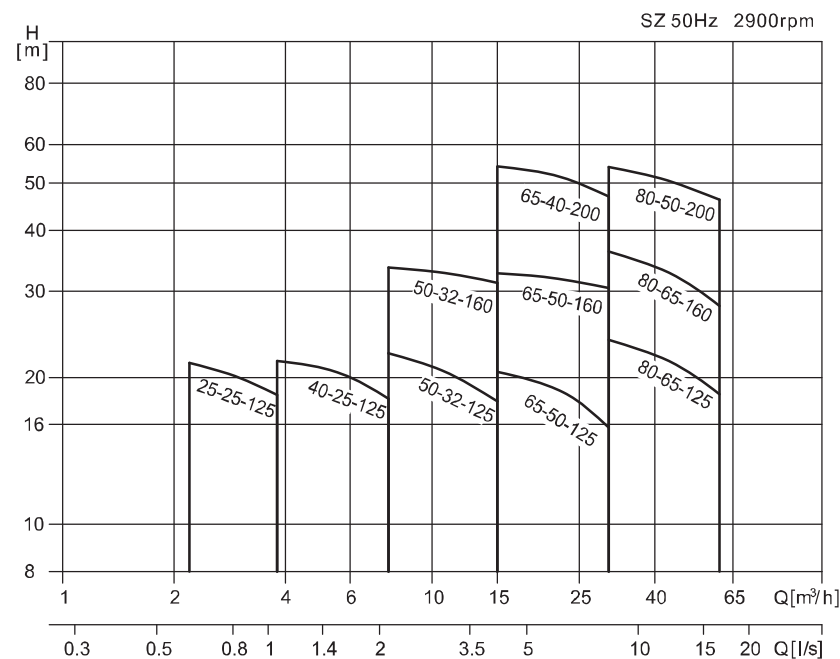

Performance table

Model	Rated flow [m³/h]	Rated head [m]	Flow range [m³/h]	Max bar [bar]	Motor power [kW]	Max efficiency [%]
SZ25-25-125	3.2	20	2.2~3.8	2.1	1.1	28
SZ40-25-125	6.3	20	3.8~7.6	2.1	1.5	41
SZ50-32-125	12.5	20	7.6~15	2.3	3	44
SZ50-32-160	12.5	32	7.6~15	3.3	4	51
SZ65-50-125	25	20	15~30	2	4	55
SZ65-50-160	25	32	15~30	3.3	5.5	60
SZ65-40-200	25	50	15~30	5.1	11	55
SZ80-65-125	50	20	30~60	2.6	7.5	62
SZ80-65-160	50	32	30~60	3.6	11	62
SZ80-50-200	50	50	30~60	5.4	18.5	63

Sectional Drawing

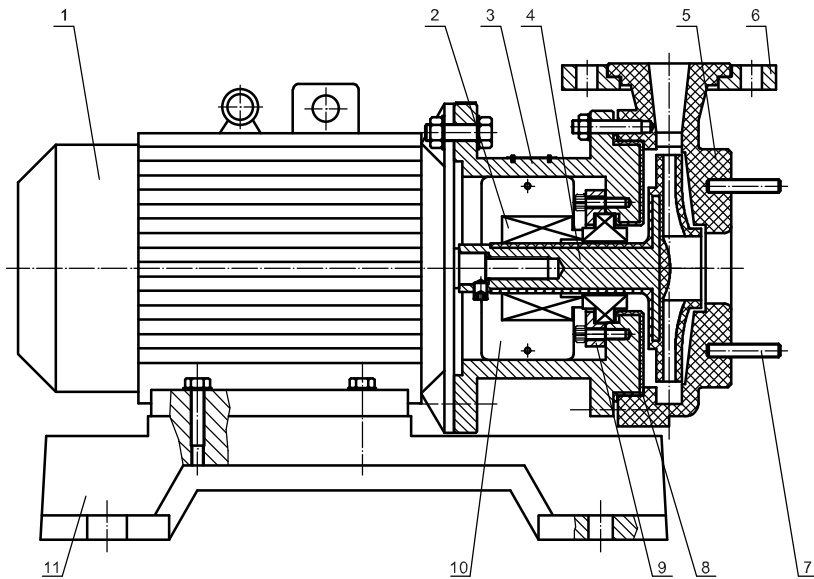

Material

No	Parts Name	Material	Code (AISI/ASTM)
1	Motor		
2	Mechanical seal	Silicon Carbide/Silicon Carbide	
3	Injection moulding pump head	HT200+F26(F46)	ASTM25B+F26(F46)
4	Impeller	Steel+F26(F46)	ASTMA570+F26(F46)
5	Casing	F26(F46)	
6	Outlet flange	HT200	ASTM25B
7	Double end studs	Stainless steel 06Cr19Ni10	AISI304
8	O-ring	FPM	
9	Seal cover	HT200	ASTM25B
10	Guard	Stainless steel 06Cr19Ni10	AISI304
11	Base	HT200	ASTM25B

SZ25/SZ40/SZ50 Performance curves

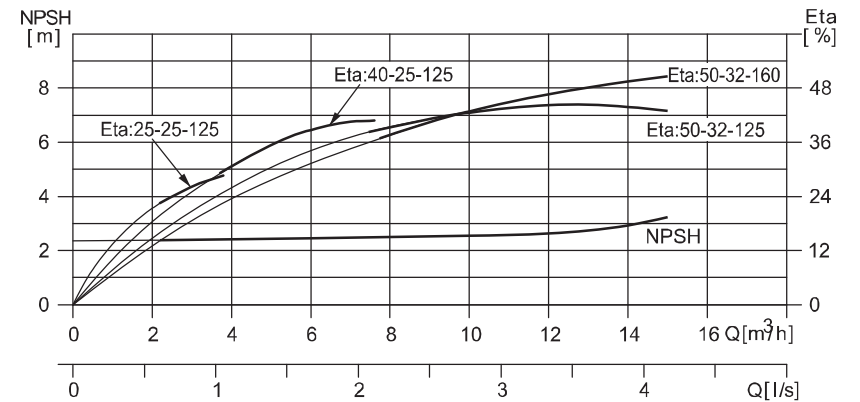
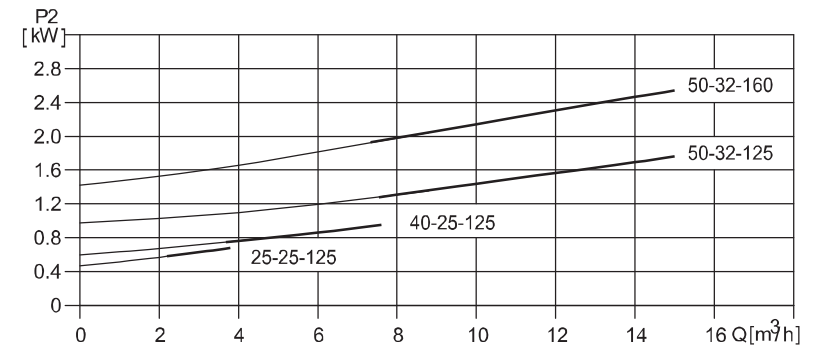
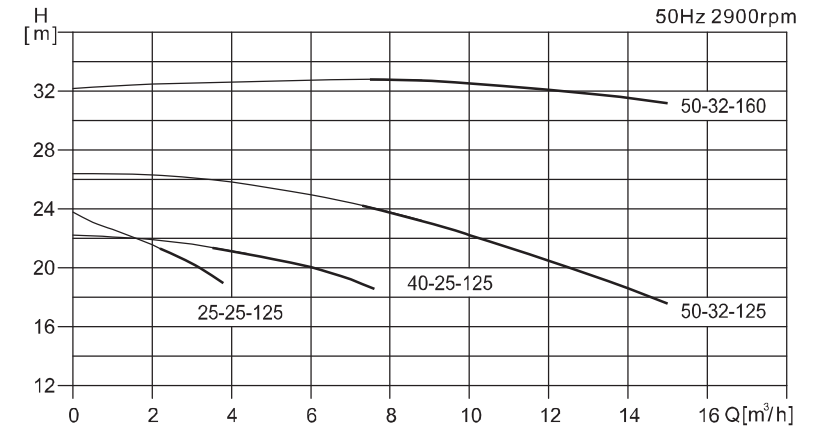

SZ65 Performance curves

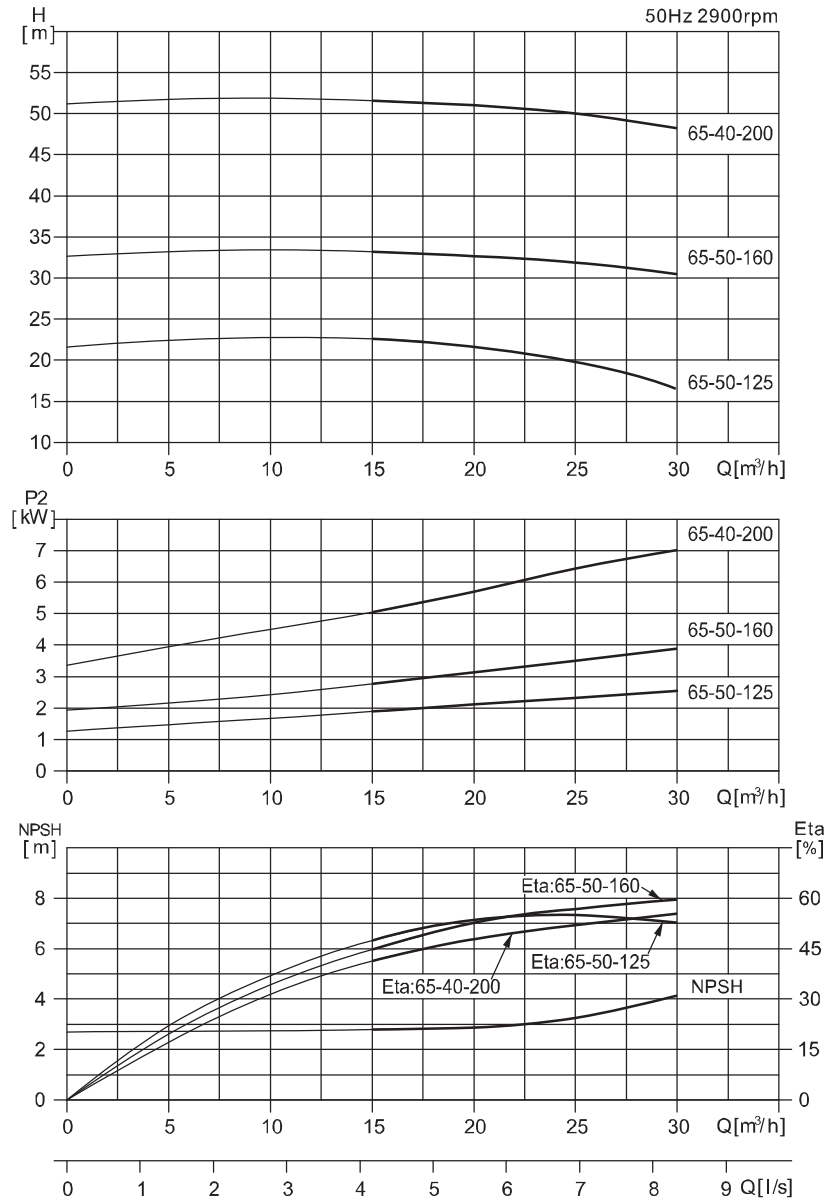

SZ80 Performance curves

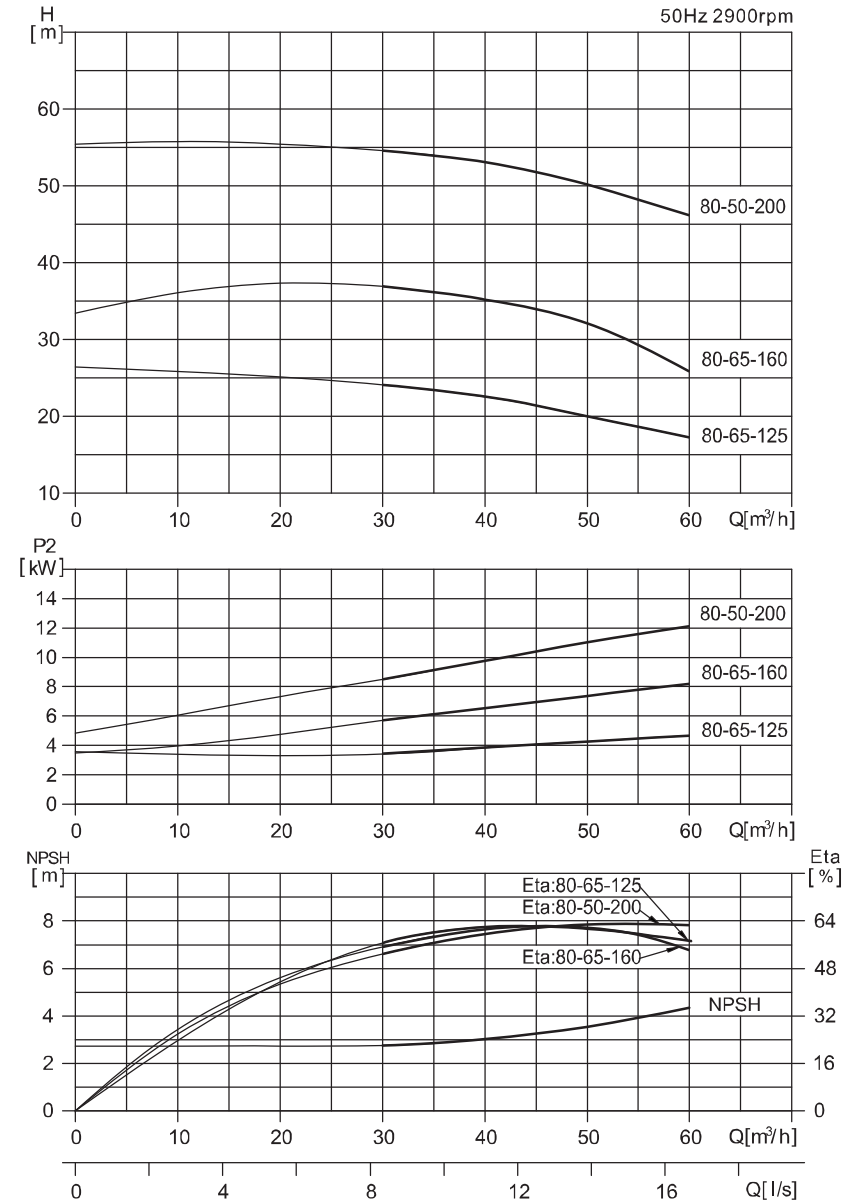

Installation sketch

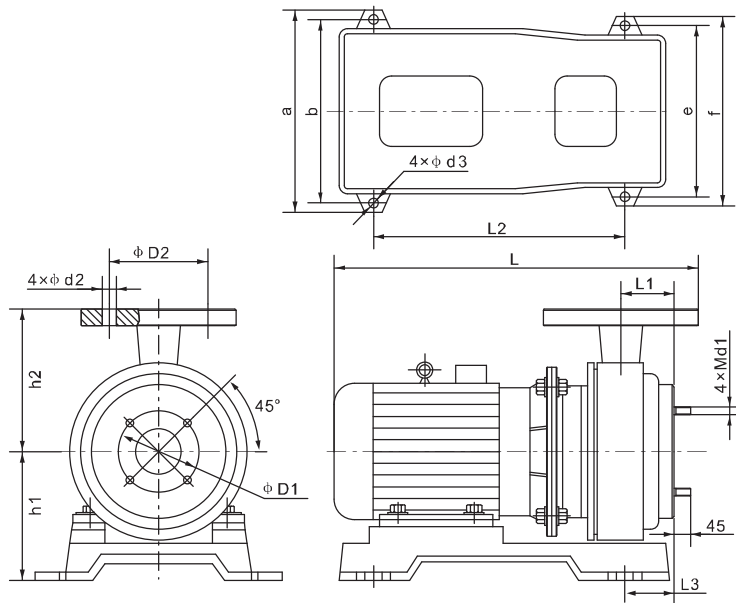

Dimensions and weight

Model	Dimensions(mm)																Weight (kg)	
	L	L1	L2	L3	D1	Inlet flange	d1	h1	h2	D2	Outlet flange	d2	a	b	d3	e		f
SZ25-25-125	457	37	300	64	75	DN25/PN6	10	164	120	100	DN32/PN10	14	265	230	15	230	265	45
SZ40-25-125	461	37	300	72	100	DN40/PN6	10	165	120	100		14	265	230	15	230	265	48
SZ50-32-125	531	43	370	79	125	DN50/PN10	14	175	140	100		14	275	235	17	235	275	74
SZ50-32-160	553	53	370	103	125	DN50/PN10	14	191	159	100	14	315	270	17	270	315	78	
SZ65-50-125	563	50	370	95	145	DN65/PN10	14	175	147	125	DN50/PN10	18	315	270	17	270	315	79
SZ65-50-160	618	51	400	88	145		14	219	165	125		18	370	330	17	290	335	113
SZ65-40-200	727	55	440	96	145		14	255	180	110		DN40/PN10	18	425	380	19	320	365
SZ80-65-125	631	52	400	88	160	DN80/PN10	14	219	165	145	DN65/PN10	18	370	330	17	290	335	123
SZ80-65-160	750	57	440	97	160		14	255	186	145		18	425	380	19	320	365	183
SZ80-50-200	797	57	440	110	160		14	255	195	125		DN50/PN10	18	425	380	19	320	365

F46、F26 Corrosion resistance table

Medium	F46	F26	Medium	F46	F26	Medium	F46	F26
Acetic acid; Benzoic acid	✓	✓	Sulfuric acid +20% fuming sulfuric acid	√/80°C	—	Titanium tetrachloride; Zinc chloride	✓	✓
Arsenic acid; Boric acid	✓	✓	oleum	✓	×	Ferric trichloride; Carbon tetrachloride	✓	✓
Carbonate	✓	√/20°C	Sulfurous acid	✓	✓	Salt solution; Seawater	✓	✓
Fluoroacetic acid	✓	—	Ammonium hydroxide; Potassium hydroxide	✓	✓	Alum (slurry); Black liquor (slurry)	×	—
Hypochlorous acid; Wet chlorine gas	✓	✓	Sodium hydroxide <20%	✓	✓	Sodium Hydrogen Sulfite	✓	✓
Chromic acid	✓	√/50°C	Sodium hydroxide <80%	✓	×	Sodium bicarbonate; Baking soda	✓	✓
Citric acid	✓	√/120°C	Calcium hydroxide	✓	✓	Sodium Hypochlorite	✓	√/20%
Cresyl acid	✓	√/65°C	Acetate solution	✓	✓	Sodium chlorate; Calcium chlorate	✓	✓
Formic acid	✓	✓	Ammonium nitrate; Barium nitrate	✓	✓	Sodium Chromate Tetrahydrate	✓	—
Glycolic acid	—	√/20°C	Sodium nitrate; Copper nitrate	✓	✓	Acetic acid aluminum	✓	✓
Hydrochloric acid	√/65°C	√/37%	Ferric nitrate	✓	✓	Bromine	✓	√/20°C
Hydrofluoric acid; Fluosilicic acid	✓	✓	Lead nitrate; Silver nitrate	✓	—	Glycerin	✓	✓
Hydrogen peroxide; Lactic acid	✓	√/20°C	Aluminum sulfate; Ammonium sulfate	✓	✓	Pyridine	✓	×
Maleic acid; Malic acid	✓	✓	Ammonium sulfate + Sulfuric acid	✓	✓	Ethyl anhydride (CH3CO)2O	✓	√/20°C
Mixed acid	✓	—	Barium sulfate; Sodium sulfate	✓	✓	Aniline dye; Aniline hydrochloride	✓	—
Oleic acid	✓	✓	Copper sulfate	✓	✓	Methane; Ethane;Propane	✓	✓
Oxalic acid	✓	√/50°C	Copper sulfate + 10% Sulfuric acid	✓	—	Nitrobenzene	✓	√/20°C
Picric acid; Stearic acid	✓	√/20°C	Ferric sulfate + 10% Sulfuric acid	✓	—	Tar and ammonia	✓	—
Unitary stone acid; Tannic acid	✓	✓	Magnesium sulfate; Zinc sulfate	✓	✓	Toluene;Sulphur trioxide	✓	✓
Nitric acid 5%~10%	✓	√/50°C	Ammonium phosphate; Sodium phosphate	✓	✓	Ethylene glycol; Epoxy ethane	✓	✓
Nitric acid <50%	✓	✓	Ammonium chloride; Barium chloride	✓	✓	Pairs of acetone. Dichloro ethanol	✓	√/20°C
Concentrated nitric acid	✓	×	Calcium chloride	✓	✓	Ethylene dioxide; Ethylene trioxide	✓	✓
Nitric acid+ 3.5% hydrofluoric acid	✓	—	Aluminium trichloride	✓	√/20%	Formaldehyde	✓	√/50°C
Phosphoric acid	✓	✓	Potassium chloride	✓	√/65°C	Freon	×	—
Phosphoric acid + 4% sulfuric acid + 1% hydrofluoric acid	✓	—	Sodium chloride; Tin chloride	✓	✓	Carbon disulfide	✓	√/20°C
Sulfuric acid<10%	✓	✓	Silver chloride; Magnesium chloride	✓	✓	Molten sulfur	✓	✓
Sulfuric acid 10% ~ 75%	✓	√/65°C	Nickel chloride	✓	✓			
Sulfuric acid 75% ~ 98%	√/80°C	√/50°C	Sulfur dichloride	✓	√/20°C			

Note: 1. √/20 means the material can be used in the medium that temperature is below 20. ✓ means workable;
× means doesn't work; — means not known.

2. √/20% means the material can be used in the 20% medium.