

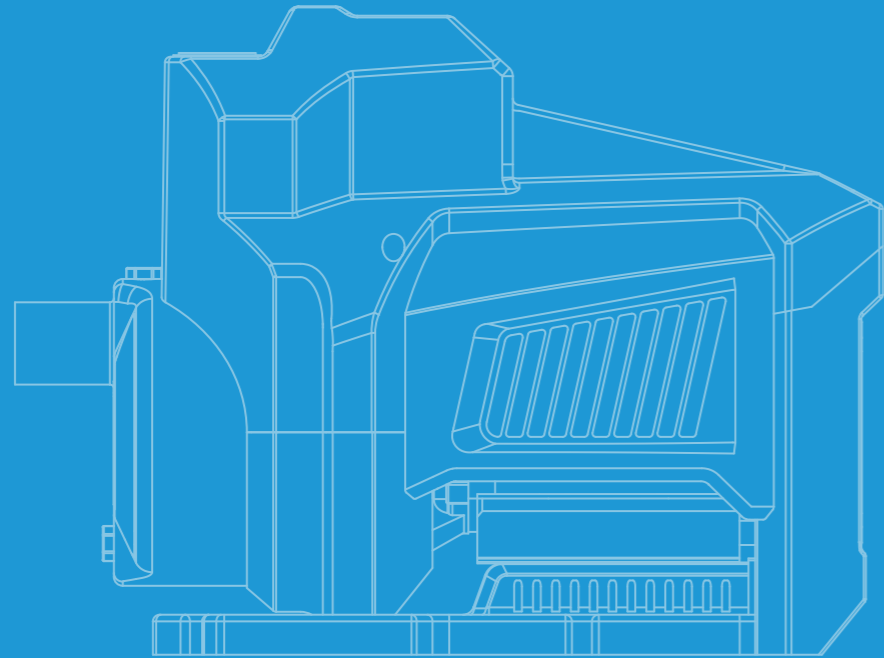

INSTRUCTIONS



**PM SERIES PERMANENT
MAGNET VARIABLE FREQUENCY PUMP**

01 PRODUCT DESCRIPTION	02 USE TYPE SELECTION	03 INSTALLATION METHOD	04 OPERATION PANEL	05 EXPLODED DIAGRAM	06 FAULT AND HANDLING	07 POST MAINTENANCE
----------------------------------	---------------------------------	----------------------------------	------------------------------	-------------------------------	---------------------------------	-------------------------------

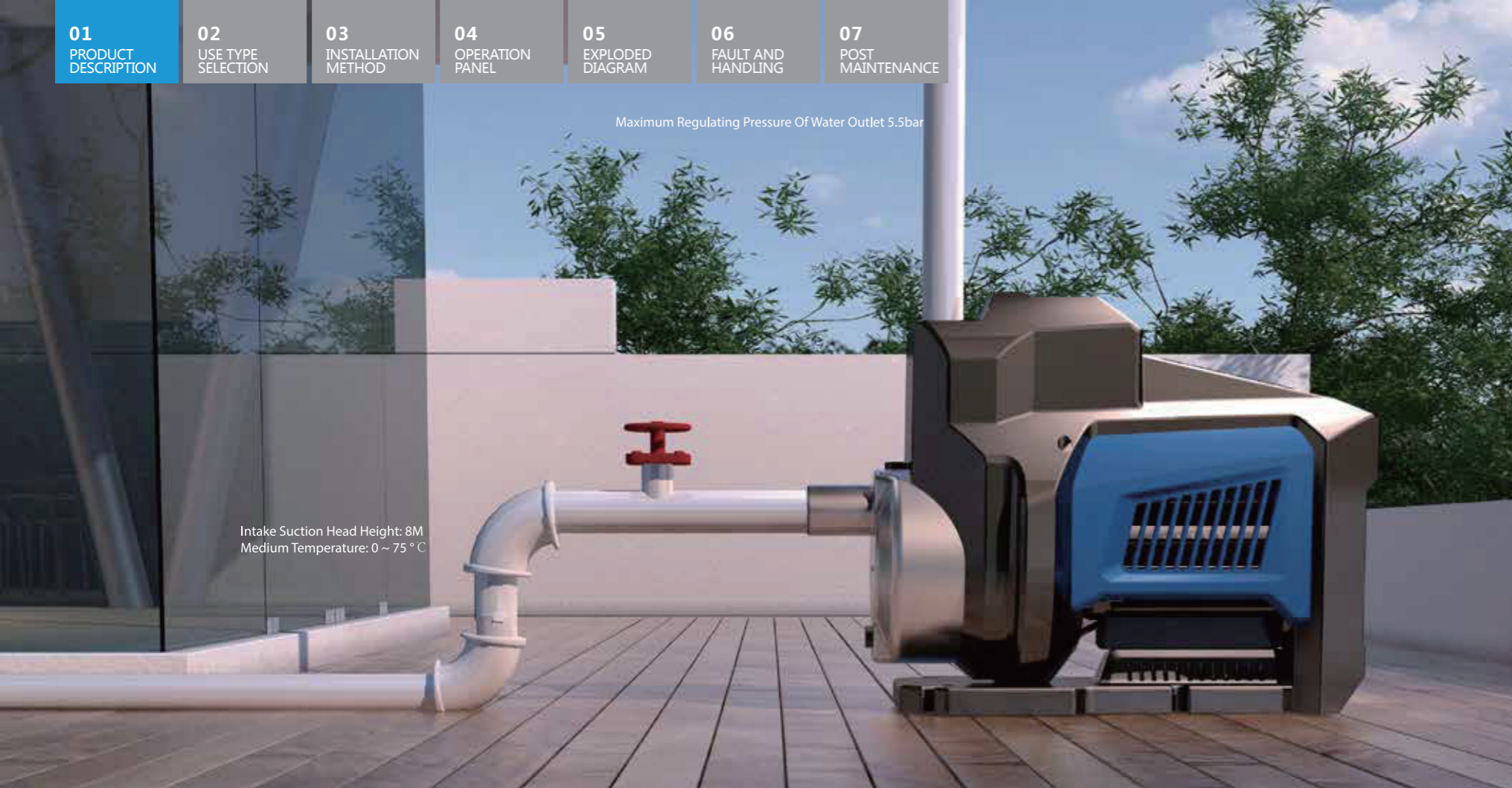

Maximum Regulating Pressure Of Water Outlet 5.5bar

Intake Suction Head Height: 8M
Medium Temperature: 0 ~ 75 °C



PERMANENT MAGNET
FREQUENCY CONVERSION



LOW NOISE BOOST



ENERGY SAVING AND
ENVIRONMENTAL
PROTECTION



MULTIPLE PROTECTION



INTELLIGENT OPERATION

PhantomPM series multi-stage centrifugal permanent magnet variable frequency pump head is made of thickened stainless steel, which is acid and alkali resistant and corrosion-resistant, effectively preventing rust water and healthy water. When the water is stopped, the microcomputer control system will automatically detect and control the motor to slow down. Intelligent constant pressure water supply, high efficiency, energy saving and power saving, to meet the water requirements of different customers.

PM SERIES PERMANENT MAGNET VARIABLE FREQUENCY PUMP



PM750S



PM550S

MODEL MEANING

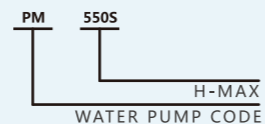

TECHNICAL PARAMETERS (CURVE CHART):

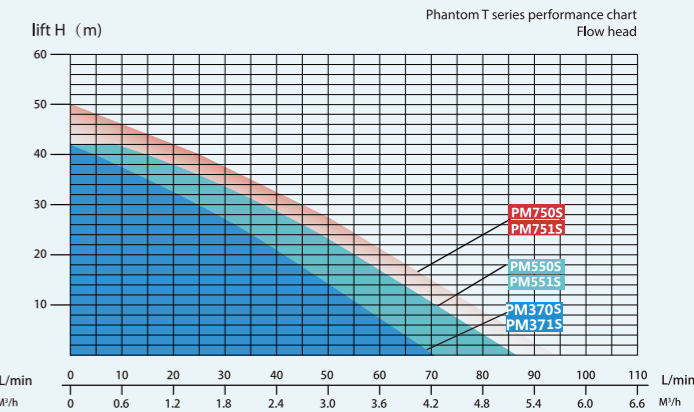
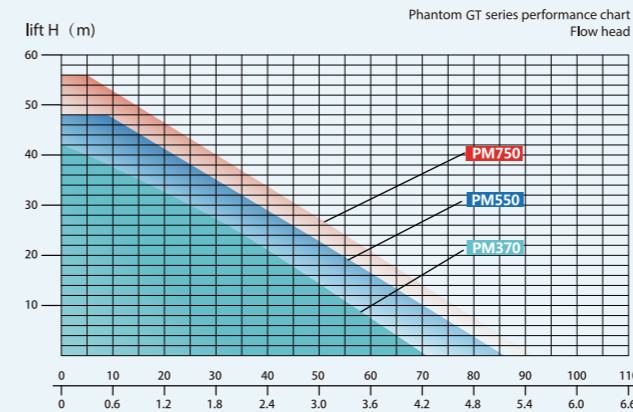

Model	Voltage (V)	Power (kW)	Max.Flow (m³/h)	Max.Head (m)	Rated Flow (m³/h)	Rated Head (m)	Piping (mm)	Maximum suction range (m)
PM370	160~260V 50/60Hz	0.37	4	40	1.8	25	25	3
PM550		0.55	5	46	3	24	25	3
PM750		0.75	5.5	55	3	28	25	3
PM370S		0.37	4	40	1.8	25	25	8
PM371S		0.37	4	40	1.8	25	25	8
PM550S		0.55	5	42	3	24	25	8
PM551S		0.55	5	42	3	24	25	8
PM750S		0.75	5.5	50	3	28	25	8
PM751S		0.75	5.5	50	3	28	25	8

PRODUCT SIZE

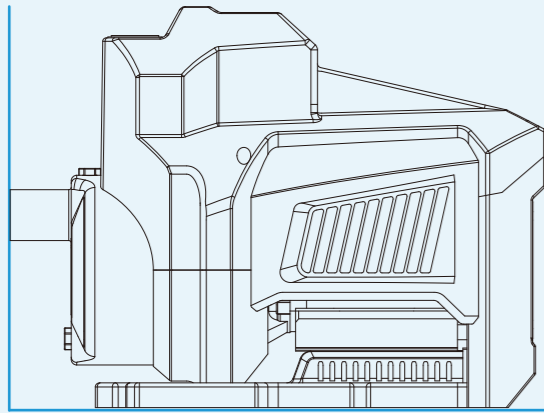

PRODUCT DIMENSIONS : 390*195*290

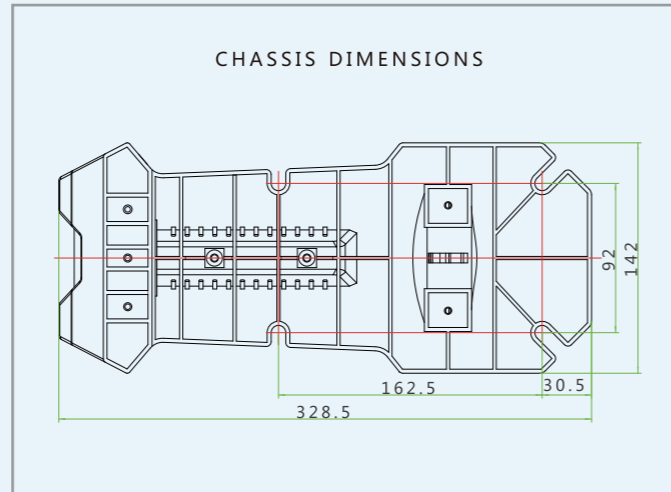

PERMANENT MAGNET PUMP HEAD



Model: PM750S

FOR THE WATER TO SAVE ELECTRICITY 50%

75°C TEMPERATURE

Power: 750W
Max-Head: 50m
Rated Head: 31m
Max.Suction Head: 8m

Max-Flow: 5.8m³/h
Rated Flow: 3.0m³/h
Piping Diameter: 25mm

Model: PM550S

FOR THE WATER TO SAVE ELECTRICITY 50%

75°C TEMPERATURE

Power: 550W
Max-Head: 42m
Rated Head: 24m
Max.Suction Head: 8m

Max-Flow: 5.3m³/h
Rated Flow: 3.0m³/h
Piping Diameter: 25mm

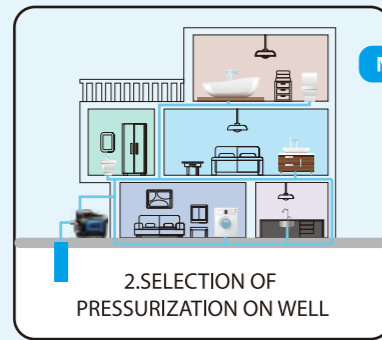
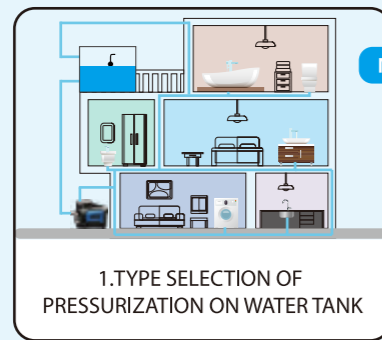

BAR	PSI	Water colum [m]/[ft]	kPa	MPa
5.5	80	55/180	550	0.55
5.0	73	50/165	500	0.50
4.5	65	45/150	450	0.45
4.0	58	40/130	400	0.40
3.5	51	35/115	350	0.35
3.0	44	30/100	300	0.30
2.5	36	25/80	250	0.25
2.0	30	20/65	200	0.20
1.5	22	15/50	150	0.15

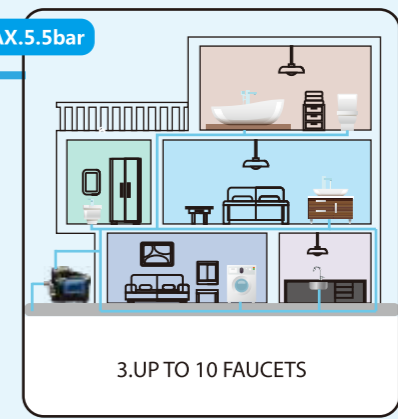

PUMP SELECTION FOR VILLA

FOR THE SELECTION OF THE TARGET ROOM, 7-8 FAUCETS ARE USED AS AN EXAMPLE. THE FLOW OF EACH FAUCET IS 0.7m³/H-0.9 m³/ H, AND THE INTERNAL PRESSURE OF THE PIPELINE IS THE CUMULATIVE SUPERIMPOSED PRESSURE. THE LOSS OF THE PIPELINE MUST BE CONSIDERED. ONE ELBOW IS EQUIVALENT TO 1 METER OF PRESSURE LOSS. BEST EFFICIENCY POINT OF WATER PUMP + INTERNAL PRESSURE OF PIPELINE - ACTUAL LOSS OF PIPELINE = FINAL CUSTOMER SELECTION (FOR POSITION 7-8 FAUCETS)

01

PRODUCT
DESCRIPTION

02

USE TYPE
SELECTION

03

INSTALLATION
METHOD

04

OPERATION
PANEL

05

EXPLODED
DIAGRAM

06

FAULT AND
HANDLING

07

POST
MAINTENANCE

PRECAUTIONS TO CHECK BEFORE INSTALLATION

- a. Sealing Ring (mouth ring) clearance;
- b. Sealing Ring and shaft sleeve radial beating;
- c. Bearing and Bearing Room;
- d. Shaft Seal Inspection: Mechanical seal form and model whether meet the requirements of the contract, whether the washing, filtering and cooling pipe installation is correct or not, if the packing is sealed, the packing should be packed separately and filled on the spot.
- e. Check whether the cooling water pipeline is blocked, it should be cleaned and kept unobstructed.

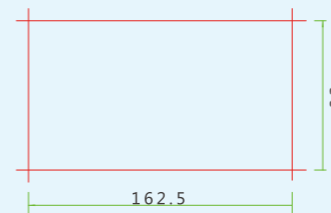

POINTS FOR ATTENTION IN FIXED INSTALLATION

- a. fixed with screws to reinforce.
- b. the base plate according to a certain distance has the screw bayonet, after the pump group leveling qualified, fastens the anchor bolt, tightens the torque and the bolt axial tension stress conforms to the standard or the stipulation request.

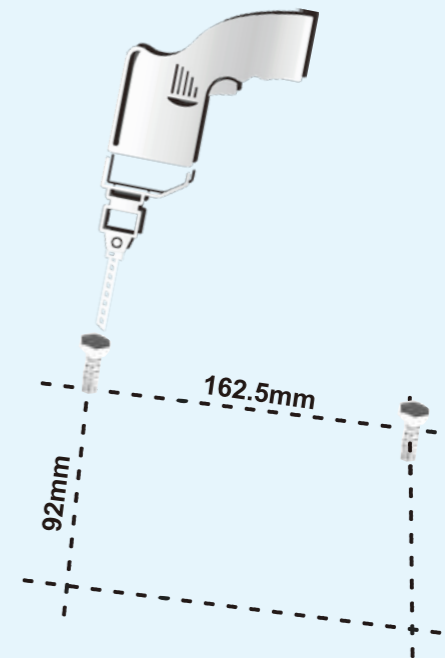

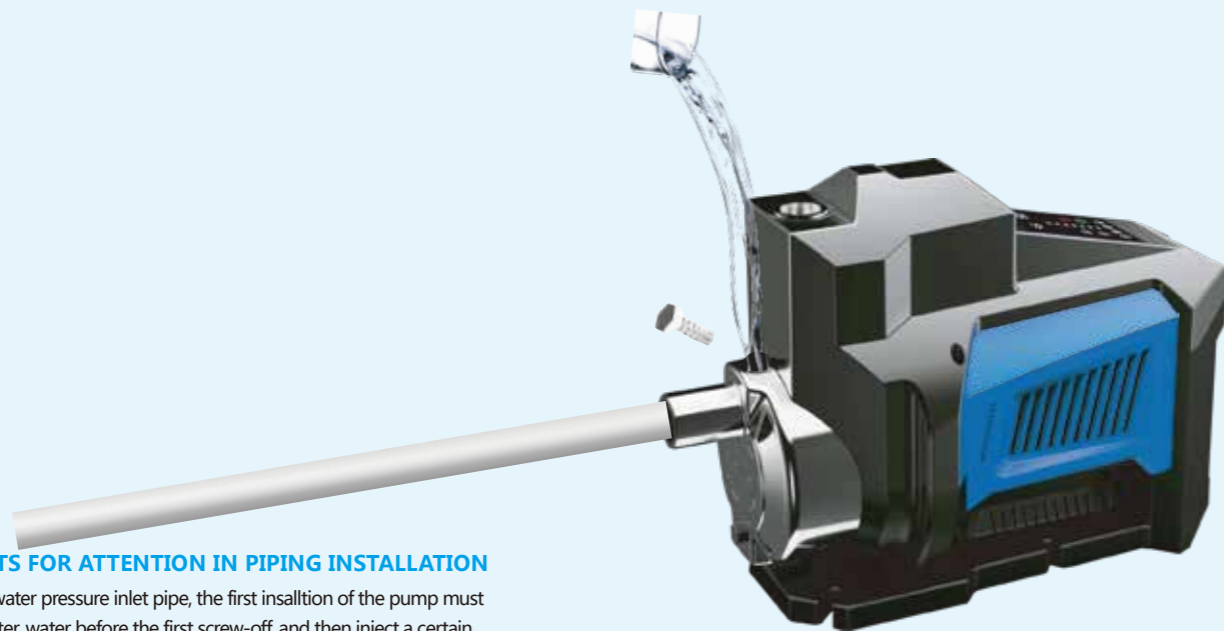

POINTS FOR ATTENTION IN PIPING INSTALLATION

- a. no water pressure inlet pipe, the first insalltion of the pump must add water, water before the first screw-off, and then inject a certain amount of water.
- b. the installation of water pump, the water inlet line is prohibited to use too soft rubber pipe to avoid sucking flat.



POINTS FOR ATTENTION IN PIPING INSTALLATION

- C. the front ready'to install the pipeline, fixed outlet.



PRECAUTIONS FOR INSTALLATION OF WATER INLET PIPE

1. There is no water pressure in the water inlet pipe, and water must be added for the first installation of water pump.
2. When installing the water pump, it is forbidden to use too soft rubber pipe for the water inlet pipe to avoid flattening.
3. The bottom valve shall be vertical and installed 30cm away from the bottom of the water to avoid sediment inhalation.
4. All connections of the inlet pipeline must be sealed to minimize elbows, otherwise it will not be able to be sucked up.
5. The diameter of the water inlet pipe shall be at least the same as that of the water inlet to prevent the hydraulic loss from affecting the water outlet performance.
6. When using, pay attention to the water level drop, and the bottom valve shall not be exposed to the water surface.
7. When the length of the water inlet pipe is more than 10m or the lifting height of the water inlet pipe is more than 4m, the diameter of the water inlet pipe must be greater than the diameter of the electric pump.
8. When installing the pipeline, make sure that the electric pump is not under the pipeline pressure.
9. In case of special circumstances, the series of water pumps are not allowed to install bottom valve, but in order to avoid solid particles entering the electric pump, the inlet pipeline must be equipped with filter.

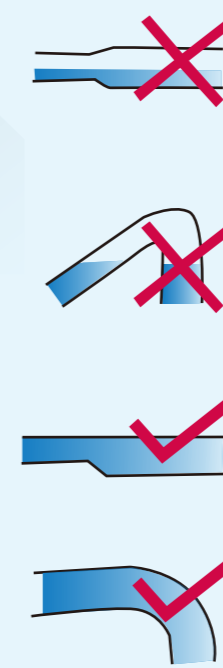

PRECAUTIONS FOR WATER OUTLET PIPELINE INSTALLATION

The outlet pipe diameter shall be at least the same as the outlet diameter to minimize the pressure drop, high flow rate and noise.

CONTROL PANEL

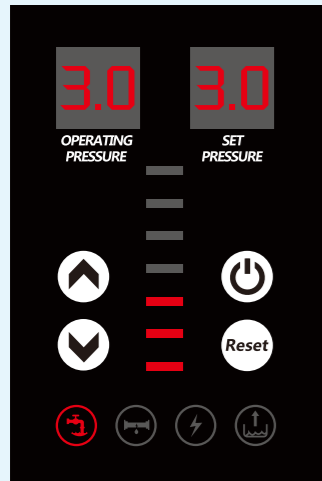

MENU USE

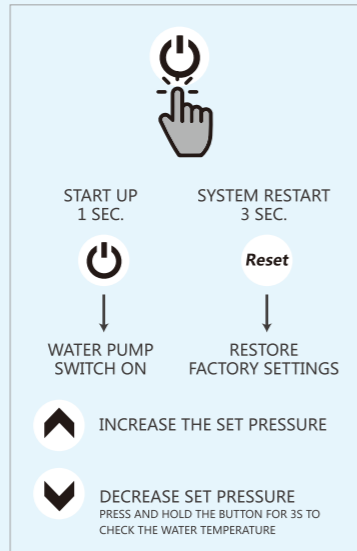

PRESSURE SETTING

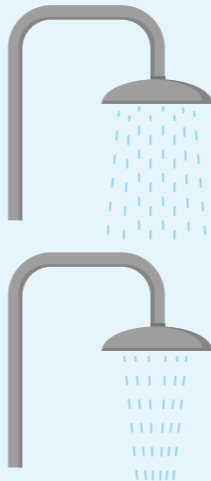



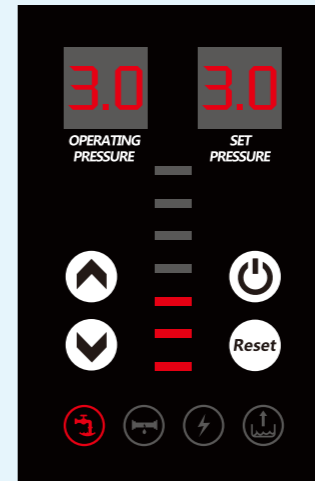

EXPLAIN:
1.PRESS THE UP AND DOWN KEYS TO SET THE REQUIRED PRESSURE VALUE

CONTROL PANEL





INDICATOR DESCRIPTION

-  → WATER PUMP OPERATION
-  → PIPELINE LEAKAGE
-  → POWER FAILURE
-  → IMPORT WATER SHORTAGE
-  → POWER BAR
THE FEWER LIGHTS,
THE MORE ENERGY SAVING

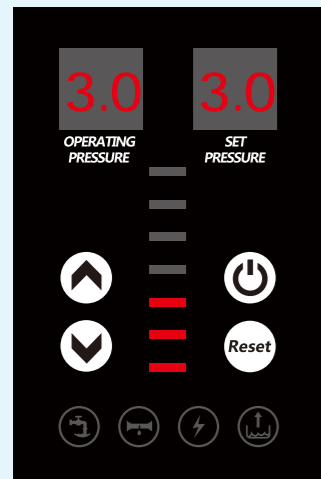
CONTROL PANEL





MODE SWITCH

Press  key 10s, Switch to rev mode,
In constant voltage mode  lights on,
In manual cycle mode  extinguished.

Remarks: 1. In speed mode, the water pump screen displays the current running speed of the water pump.
2. In this mode, the water pump will not stop.
Only when the pressure sensor or controller fails, this mode can ensure that the water pump temporarily uses water.



-  Increase pump speed
-  Decrease pump speed

CONTROL PANEL

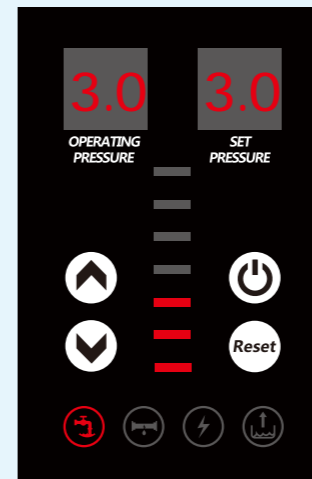

RESET

Press **Reset** key 3s, All parameters are restored to factory settings.

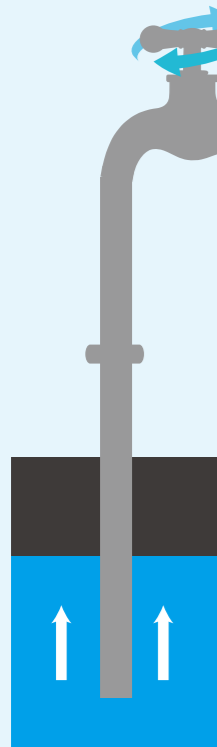

WELL

NORMAL WATER
OUTLET WITHIN
6 MINUTES

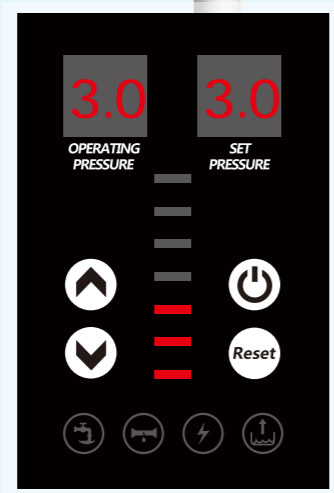

START BUTTON TO START THE PUMP
THREE SECOND DELAY AFTER POWER UP

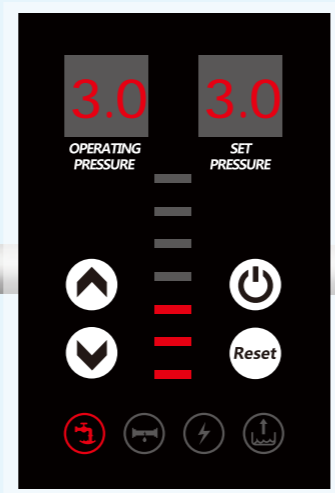

1.THE PUMP IS RUNNING NORMALLY AND
THE INDICATOR LIGHT IS ON
2.ALL WATER POINTS ARE CLOSED, THE WATER
PUMP STOPS RUNNING, AND THE POWER
INDICATOR LIGHTS ARE ALL OFF



**T SERIES PERMANENT
MAGNET VARIABLE FREQUENCY PUMP**



Double pump online instructions

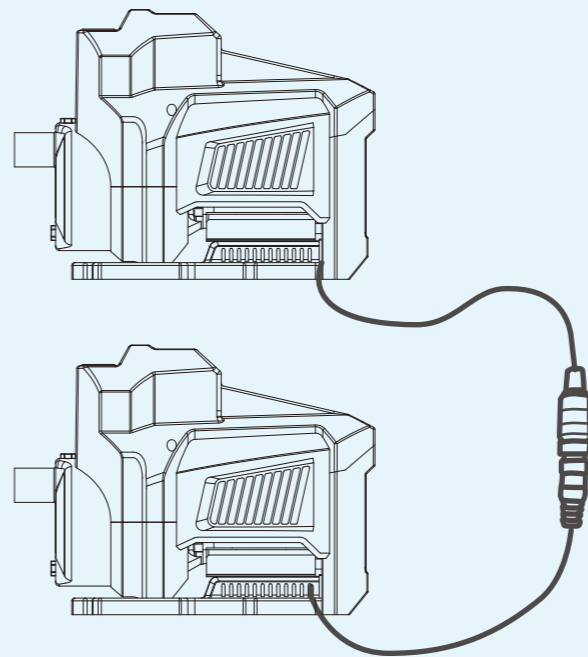

Double pump online instructions

- A. 2 pumps in parallel connected to the inlet pipe and outlet pipe, pressure pipe need to be more than DN32, Outlet pipe should be more than DN25.
- B. each insert 2 pumps online with usb data cable terminal, and locking

The control panel

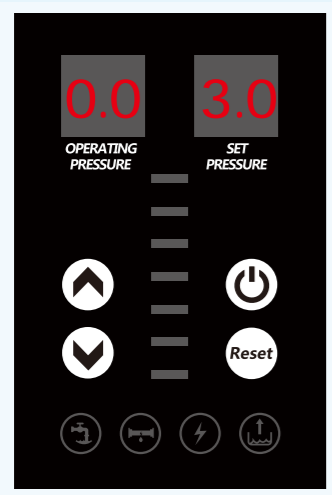

Use menu

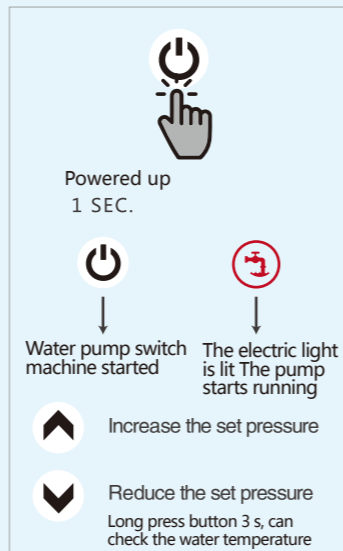

The control panel

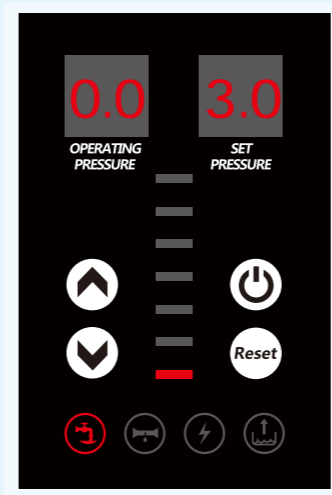

Note:
2 pumps set pressure to be consistent, can't
The size is different.

Directions for use



Enter the online features:

Pick 1 pumps as a host, long press the button 3 s, into the online setting pattern, the electricity run indicator in the flashing state, on behalf of the online success.

Exit the online features:

Long press the button 3 s host panel, the red light to stop flashing, representatives have withdrawn from the online mode.

Operation mode:

- A. when the host running 0.2 bar pressure below the set pressure, the no. 2 machine automatic startup, automatically adjust the pressure to the set pressure value.
- B. when the tap all closed, the pump stop running; To open the faucet, no. 2 machine start, when the machine run 2 pressure below the set pressure is 0.2 bar, the host start automatically.
- C. 2 pumps used interchangeably, service life is the same, when one pump fails, automatic exit online function.

EXPLODED DIAGRAM

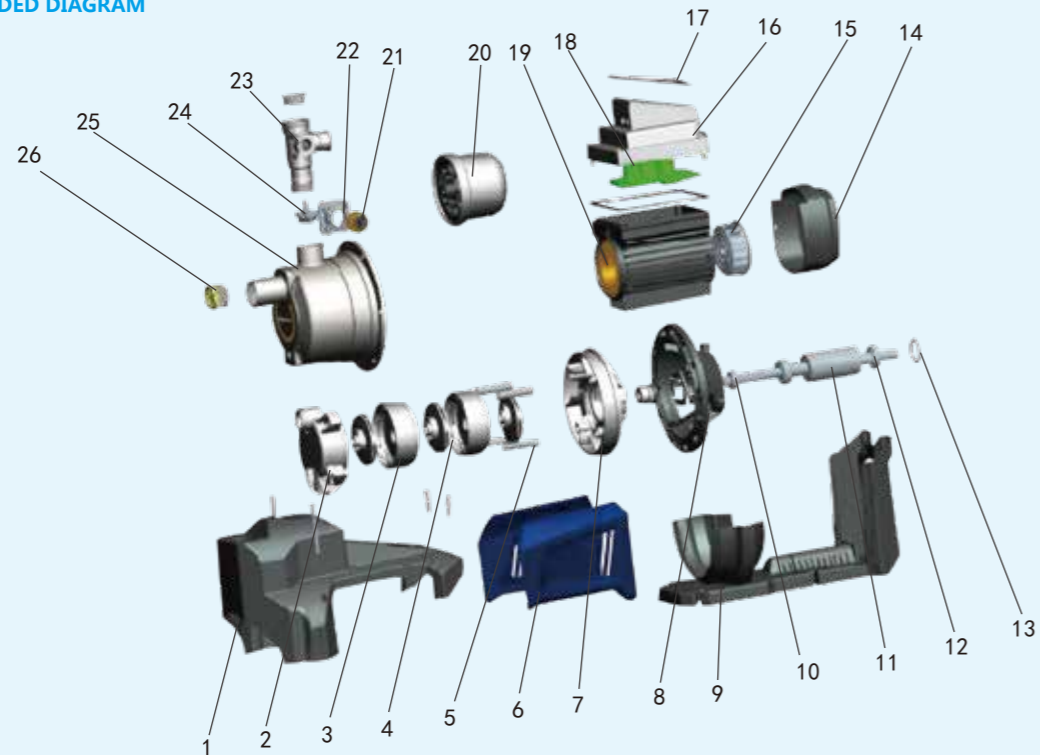

EXPLOSION CHART

POS	PART	POS	PART
1	Hull	14	Fan cover
2	Water inlet Guide glade	15	Fan
3	Guide glade	16	Capacitor box
4	Impeller	17	Gland
5	Prop	18	Controller
6	Radiation fin	19	Stator
7	Seal holder	20	Overhead tank
8	Pump support	21	Transducer
9	Motherboard	22	Sensor bracket
10	Water proof gland	23	Bottom bracket
11	Rotor	24	Check valve
12	Bearing	25	Pump body
13	Spring Washer	26	Check valve

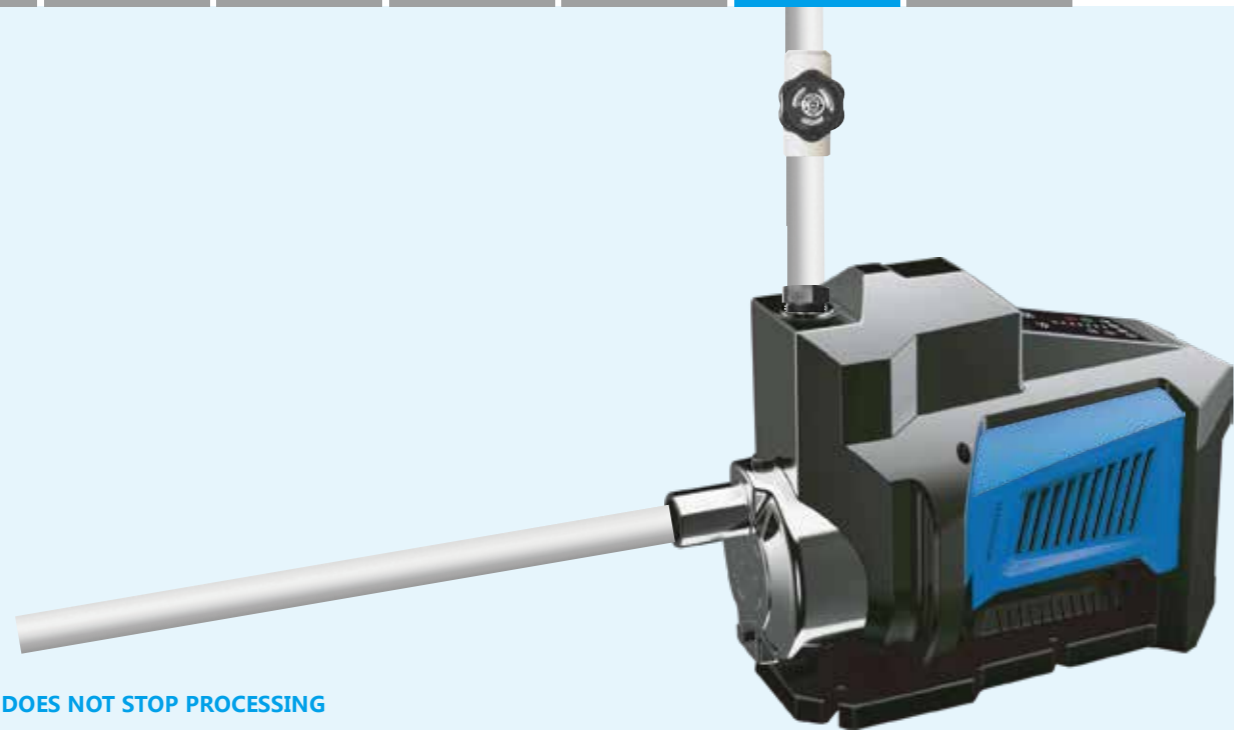

PUMP DOES NOT STOP PROCESSING

- a. Close the outlet valve, If the pump can stop, Check water points for leaks, Or the valve is not closed tightly; If the pump still does not stop, Check the pump check valve for stuck, Is the pressure tank air pressure sufficient, The standard value is 1.6Bar. Open the water injection bolt to remove air.
- b. Check if the pump is in Speed mode, If in rev mode, Press and hold the reset button for 3s, Return to stress mode.



THE WATER PUMP DOES NOT START PROCESSING

- a. Whether the water pump is in the state of water shortage protection.
- b. Whether the water pump is in the state of overvoltage protection.
- c. The set pressure of the water pump is too low, and the pressure value needs to be increased (the pressure of the tap water is too high, which will also cause the water pump not to start).
- d. If the water pump is installed outdoors, check whether the water pump has been submerged in water. Damage to the motor and controller will also cause it to fail to start.
- e. Check whether the fan blades can rotate after the pump, the water quality is too turbid, the impeller is stuck, and the pump does not start.

DISASSEMBLY AND ASSEMBLY OF OUTLET CHECK VALVE



INLET CHECK VALVE DISASSEMBLY METHOD

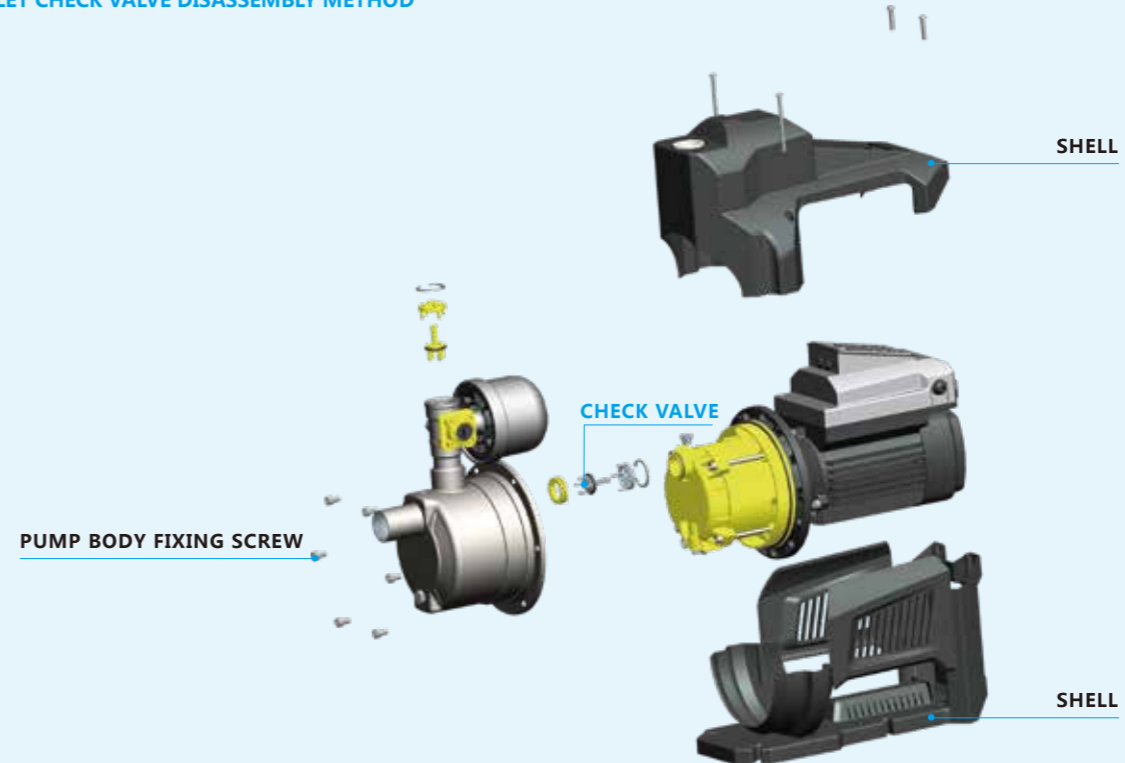

O-RING DISASSEMBLY METHOD

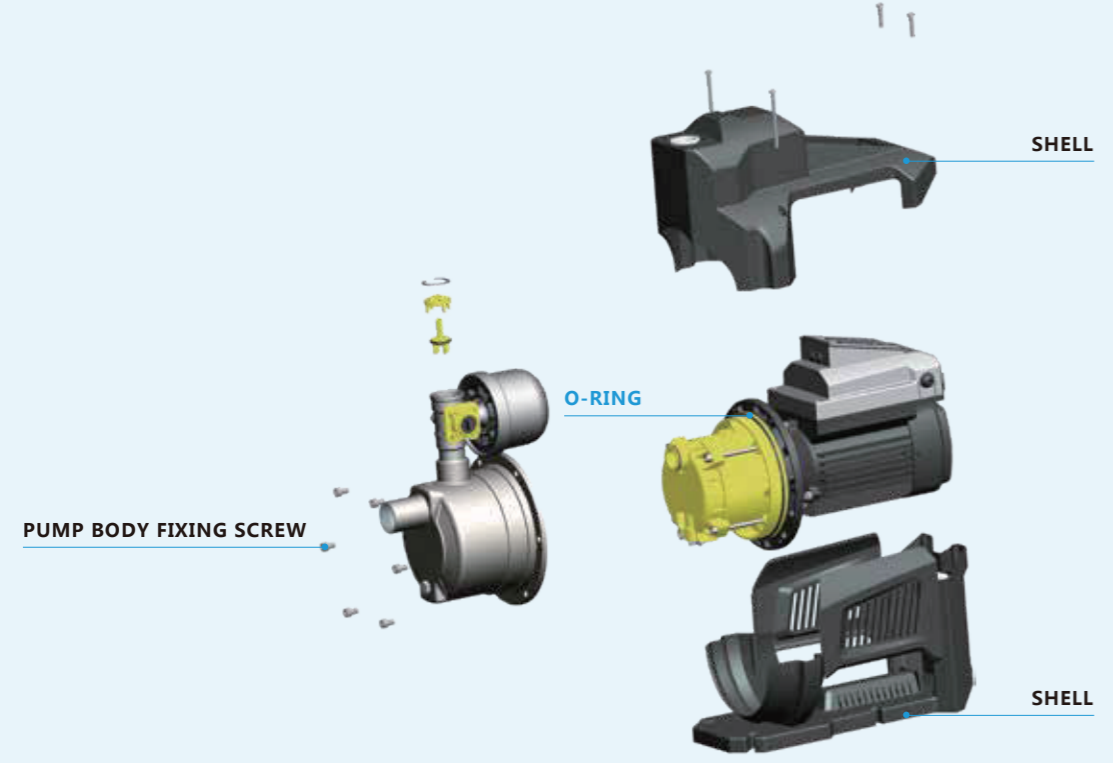

MECHANICAL SEAL DISASSEMBLY METHOD

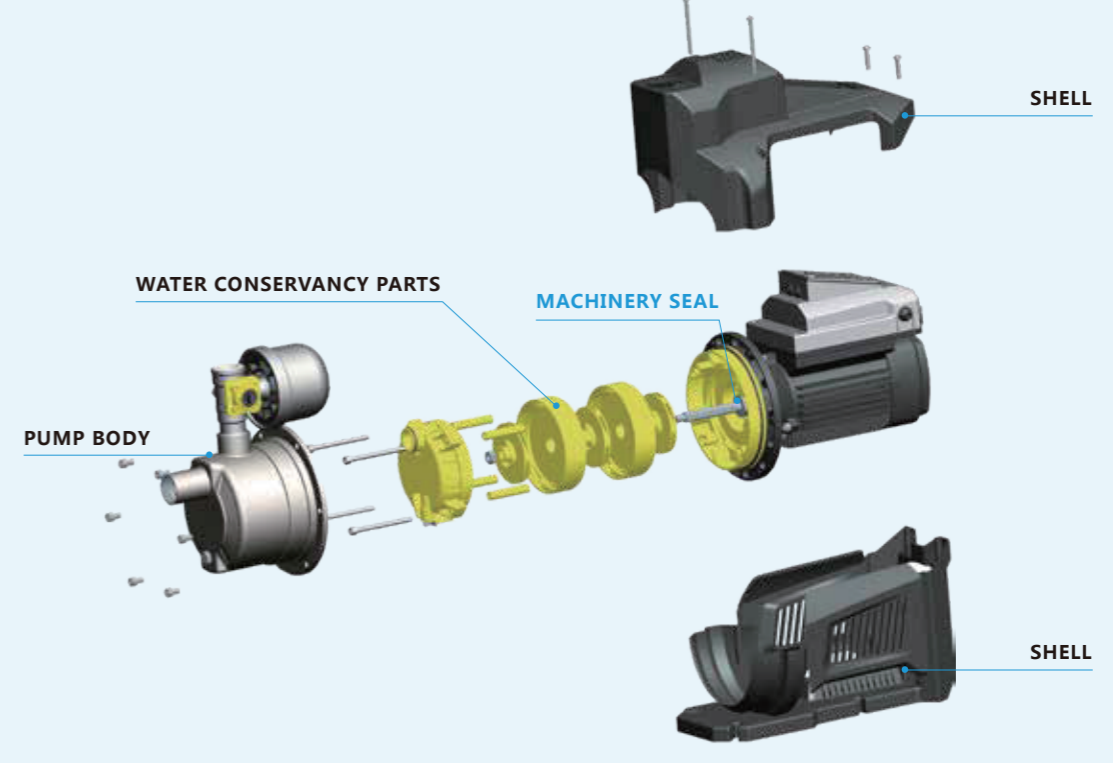

SENSOR DISASSEMBLY METHOD

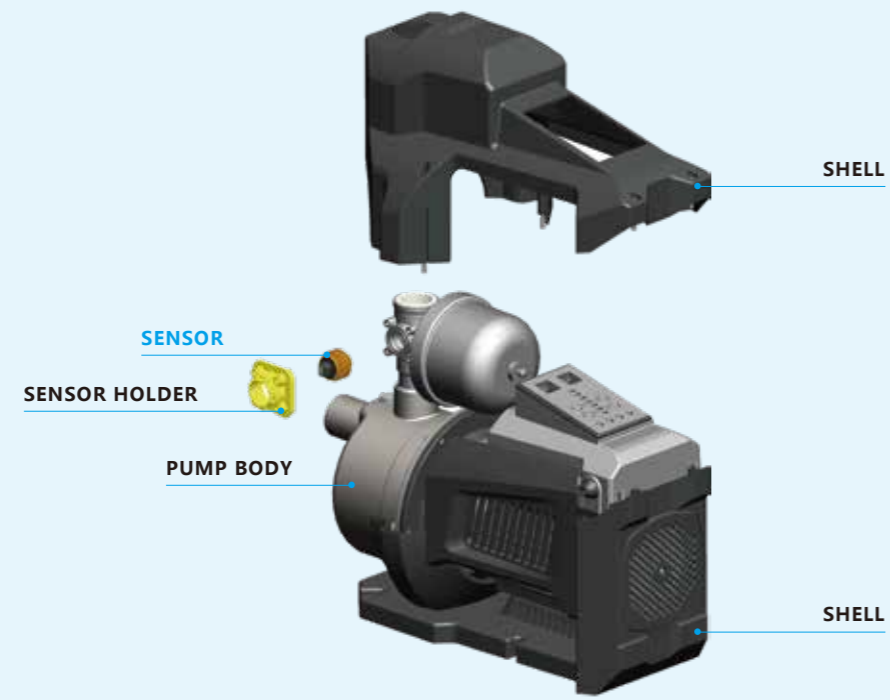

PRESSURE TANK DISASSEMBLY METHOD

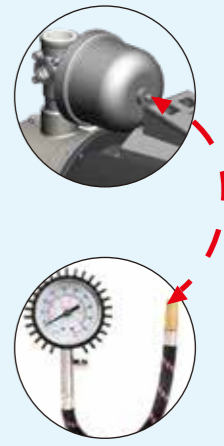
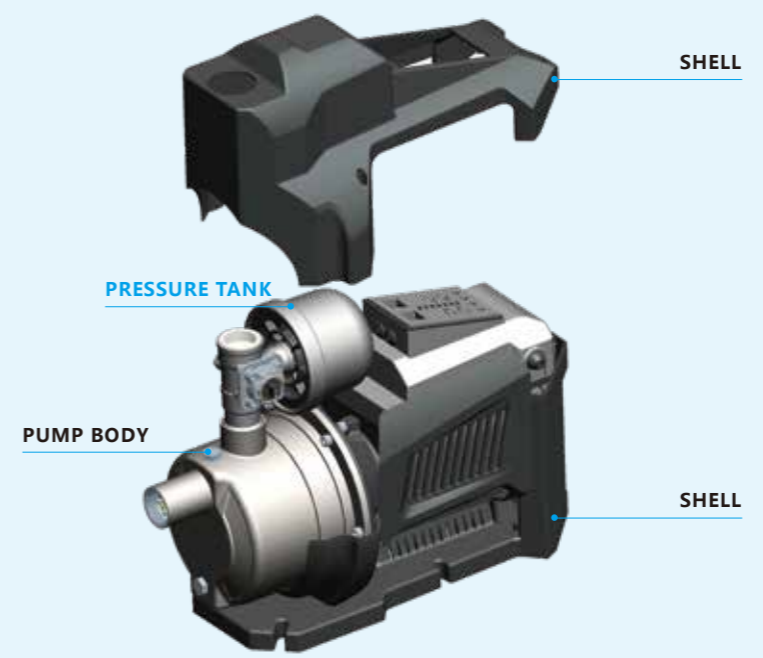

The barometer is used to inspect pressure tank pressure, if the air pressure is low at 1.6 bar, inflatable 1.8 bar.

01

PRODUCT
DESCRIPTION

02

USE TYPE
SELECTION

03

INSTALLATION
METHOD

04

OPERATION
PANEL

05

EXPLODED
DIAGRAM



06

FAULT AND
HANDLING

07

POST
MAINTENANCE



FACTORY MENU KEY OPERATION. (THE FACTORY MENU IS NOT RECOMMENDED FOR USERS TO OPERATE DIRECTLY. PROFESSIONALS OPERATE)

OPERATE	OPERATION METHOD	REMARK
enter factory menu	Simultaneously long press  key to enter the factory menu.	
Factory menu toggle	After entering the factory menu , Simultaneously long press  key or short press  toggle.	
Factory menu exit	After 10 seconds of no operation, it will automatically exit the factory mode.	

FACTORY MENU CONTENT

MENU CONTENT	MENU SIGN	DEFAULTS	WHETHER TO RESTORE WHEN RESTORING TO FACTORY MODE	MENU DESCRIPTION	REMARK
Non-stop fault parameters	P	0.1	YES	Under the premise of checking that the pipeline is completely leak-proof, and there is no shutdown failure, increase this value. Increase by 3 each time, preferably not more than 30, increasing this value will increase the fluctuation of shutdown detection. Increase this value, when the water is stopped by mistake, please increase the following parameter of wrong stop	
Error stop fault parameters	t	10	YES	In case of accidental shutdown of water, increase this value by 3 each time, and increase it successively.	
leak prompt switch	F5	1	YES	1: Leakage prompt on, 0: Leakage prompt off	
Voltage fault misjudgment parameters	F7	3 or 2	YES	If the voltage value is correct, this value can be increased to eliminate the misjudgment of the voltage fault. This parameter is the voltage fault count value, do not increase it too much, it will easily lead to the failure of the voltage protection of the driver, resulting in damage to the driver. For PFC models, add 1 each time, and for non-PFC models add 3 each time. If invalid, please restore the default value.	
Cryogenic protection temperature	A0	3	YES	When the water temperature is lower than this value, it enters into low temperature protection	
High temperature protection temperature	A1	75	YES	Water temperature higher than this value enters high temperature protection	

COMMON FAULT CODES AND TROUBLESHOOTING

ERROR CODE	CORRESPONDING FAULT	TROUBLESHOOTING
E1	Panel and motherboard communication failure	Please check whether the panel cable is connected well, and try plugging and unplugging again. If it cannot be resolved. The panel or motherboard has failed.
E2	stall	1. Please try to turn the fan blade to see if the water pump impeller is stuck.
E3	voltage failure,  icon lights up	Please check with a multimeter
E4	Outlet pressure sensor failure	Check whether the lower pressure sensor interface is in poor contact, check the lower interface, and re-plug it. If it still can't be solved, replace the pressure sensor.
E5	Controller failure	1. Power off, wait for the panel light to go out, then power on again. 2. If it still cannot be recovered, the motor or driver board is damaged.
E6	lack of phase	Check whether the motor wire is connected well. Use a multimeter to measure the resistance of the motor wire and see if there is any disconnection.
E7	overcurrent	1. Check if there is a short circuit in the motor wire. 2. Check the voltage resistance of the motor to see if the voltage resistance is not enough. 3. Re-power on and test, the motor is good, maybe the driver is damaged due to accidental impact.
E9	water temperature protection	Check whether the water temperature is abnormal
E10	lack of water,  icon lights up	Check whether the water is really lacking. If there is water, check the water flow switch for models with a water flow switch. For models without a water flow switch, you can enter the factory menu to adjust the water shortage pressure and adjust it to the current pressure.
E11	leakage,  icon lights up	Check whether the pipeline is leaking, or whether the check valve is leaking, it does not affect the water use, it only serves as a reminder.
E12	Driver board overheating fault	Wait for the temperature of the drive to drop, and automatically resume operation, or move the pump to a cool and ventilated place.

01

PRODUCT
DESCRIPTION

02

USE TYPE
SELECTION

03

INSTALLATION
METHOD

04

OPERATION
PANEL

05

EXPLODED
DIAGRAM

06

FAULT AND
HANDLING

07

POST
MAINTENANCE

WATER PUMP MAINTENANCE



(1) MAINTENANCE IN OPERATION

1. The inlet pipe must be full of liquid, and it is forbidden to operate the pump in the state of cavitation.
2. Regularly check the motor current value, which shall not exceed the rated current of the motor.
3. After long-term operation of the pump, due to mechanical wear, the noise and vibration of the unit may increase, leakage may occur, and the performance may decline. At this time, the pump shall be shut down for inspection. If necessary, vulnerable parts (such as bearings, mechanical seals, impellers, etc.) can be replaced. The overhaul period of the unit is generally one year.

(2) MECHANICAL SEAL MAINTENANCE

1. The mechanical unsealing lubrication shall be clean and free of fixed particles.
2. It is forbidden to work under dry grinding.
3. Before starting, turn the pump (motor) for several circles to prevent the graphite ring from breaking and damage due to sudden starting.
4. The seal leakage tolerance is 3 drops / min, otherwise, it shall be repaired.
5. When repairing and assembling the mechanical seal, avoid contacting with oil substances, and use soapy water, detergent, etc. to lubricate and reduce resistance.

PRODUCT AFTER SALES
WARRANTY CERTIFICATE

User name : _____ User phone: _____

User address : _____ Date of purchase: _____

Name of unit sold: _____ Phone number of :
the company sold _____

Address of selling unit: _____